



ULTRAFLO 2:1 RATIO MULTIFLUID PNEUMATIC PUMP

Particularly suitable for the distribution of low viscosity fluids such as oil, diesel, urea (AdBlue/AUS32), antifreeze and windshield liquid, but also aqueous solutions with detergents or disinfectants.

They are not suitable for distributing petrol, solvents, flammable liquids or particularly aggressive or corrosive fluids.

The high flow performance allows the transfer of large volumes of fluid at a short/medium distance.

SPECIFICATIONS:

Brand	Ultraflo
Dimensions	50x12x13
Weight	3 Kg
Delivery at free outlet	(7 bar) 50L/min
Air pressure	3-7 bar
Air consumption	200-250 L/min
Suction connection diameter	42 mm
Air inlet connection	F. 1/4 G
Suction connection	F. 1 G
Outlet connection	20 mm
Total length (mm)	425



PART NO.

AF-AE-DP2101

ULTRAFLO 2:1 Ratio Multifluid Pump Only

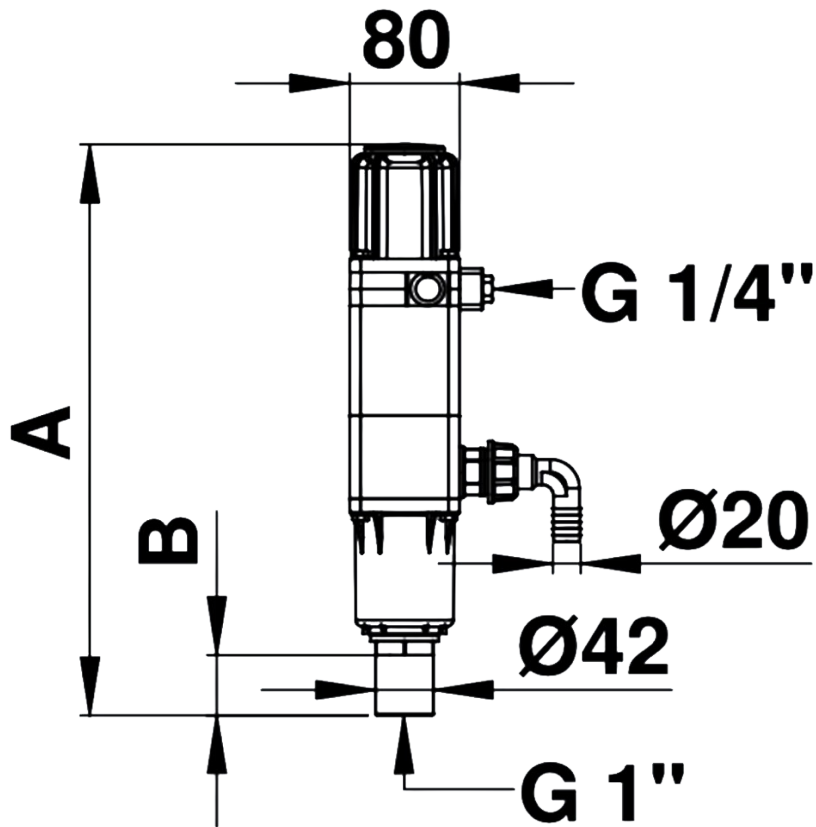

DP21

WATER SOLUTIONS
SAE 20 (ISO vg 68) oil • T = 16°C

